

Thermo-Pneumatic Fire Protection System



Thermo-Pneumatic Fire Protection System

This diagram shows a typical system. Although each system is unique, the placement of each component is typical of most systems.

Individual components are described in greater detail on their respective data sheet(s).

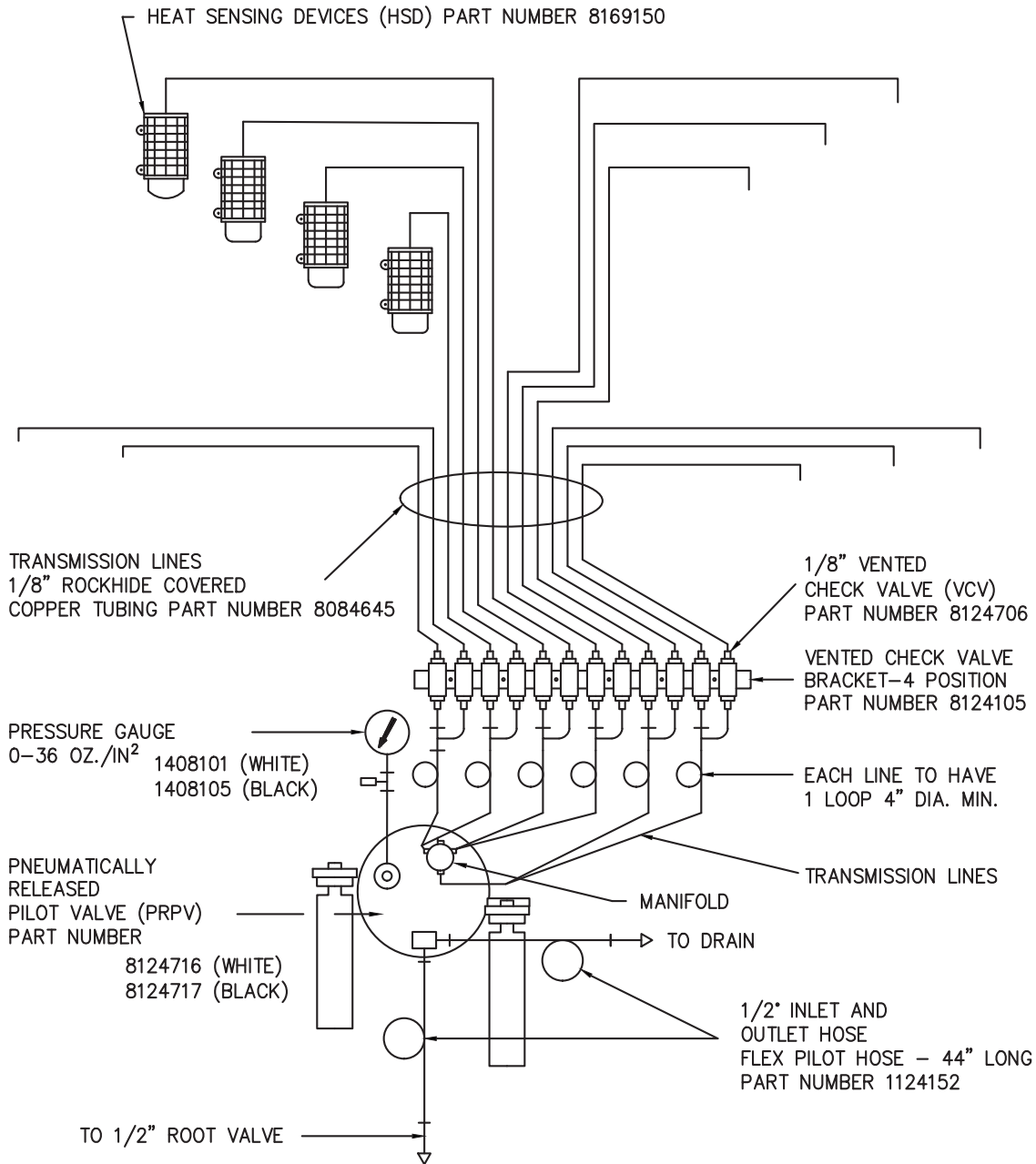

Thermo-Pneumatic Fire Protection System Parts List



DESCRIPTION	NSN #	PRPV P/N	FORMER P/N	WEIGHT
COMPONENTS				
Pneumatically Released Pilot Valve Assy w/ Flex Hose	4210-00-575-9297	-	124-300A	20lb-10oz
Flex hose - 44" (PRPV)	-	1124152	124-52	3lb-2oz
1/8" Vented Check Valve	4210-00-399-2532	8124706	124-1000	11.5oz
Vented Check Valve Bracket (4 position)	-	8124105	124-1050	1lb-4.1oz
Heat Sensing Device - 165° Link (HSD)	4210-00-111-7020	8169150	124-150	2lb-15oz
Rockhide Tubing (100 ft Roll)	4710-00-039-5702	8084645	8084645	4lb-8oz
Rockhide Tubing (1000 ft Roll)	4710-00-039-5702	8084646	8084646	45lb
Flex Hose Adapter	-	8124155	124-55	5.7oz
REPLACEMENT PARTS				
36oz Reading Gauge (PRPV), White Face	6685-01-260-7933	1408101	79-861	5.3oz
Reset Key (PRPV)	-	8124048	134-307	1.9oz
165° Fusible Link (HSD)	-	1169160	169-60	0.4oz
INSTALLATION TOOLS				
Tool Set consisting of: <ul style="list-style-type: none"> • 1-Box • 2-Flaring Tools • 2- Wrenches • 1-File • 1-Identification & Order Sheet 	5180-00-343-2016	8124550	124-550	14.2oz
Link Tool	-	8169170	169-170	9oz
FITTINGS				
Fitting Assortment consisting of: <ul style="list-style-type: none"> • 1-Box • 8-Tubing Tees • 8-Connectors • 4-90° Ells • 4- Brass Plugs • 4-Couplings • 80-Terminal Nuts 	-	8124560	124-560	16.5oz
1/8" Brass Terminal Nut	-	1080056	80-56A	.08oz
1/8" Tubing Coupling with Terminal Nuts	-	8084609	S84-111	.32oz
1/8" Tubing Tee with Terminal Nuts	-	8084610	S84-112	.61oz
1/8: Brass Plug	-	1087507	87-507	.08oz
90° Elbow with Terminal Nut	-	8084624	S84-118	.56oz
Connector with Terminal Nut	-	8084623	S84-117	.28oz
TESTING				
HSD Test Fitting - Male Branch Tree	-	8169141	169-141	2.1oz
HSD Test Fitting - Street Tee	-	8169142	169-142	1.7oz
9" Manometer Test Set	-	8068701	68-100B	7oz
18" Monometer Test Set	6685-00-526-9192	8069701	69-100A	11oz
Pulse Generator	-	8169161	169-161	2lb

Pneumatically Released Pilot Valve (PRPV)

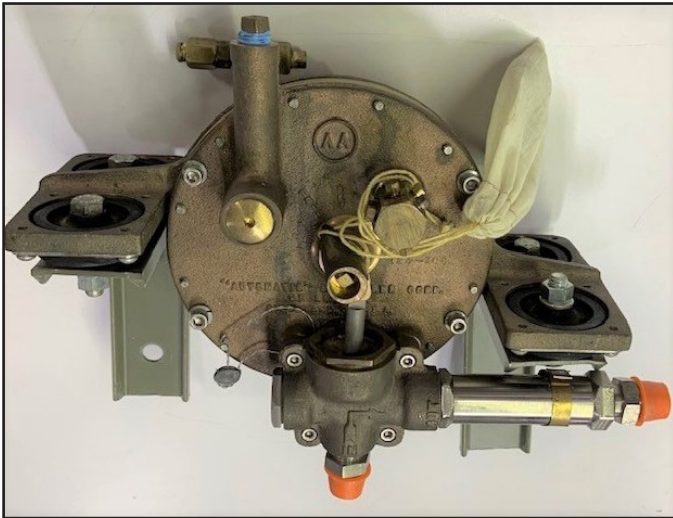

Part Number 8124716

The Pneumatically Released Pilot Valve (PRPV) is designed to provide the pilot pressure necessary to operate the sprinkler valve.

NSN Number 4210-00-575-9297

The PRPV complies with BUSHIPS Dwg. No. 124-300 (5201-S4803-2816)

Formerly P/N 124-300-1

Shown less Flex Hoses and Air Gauge

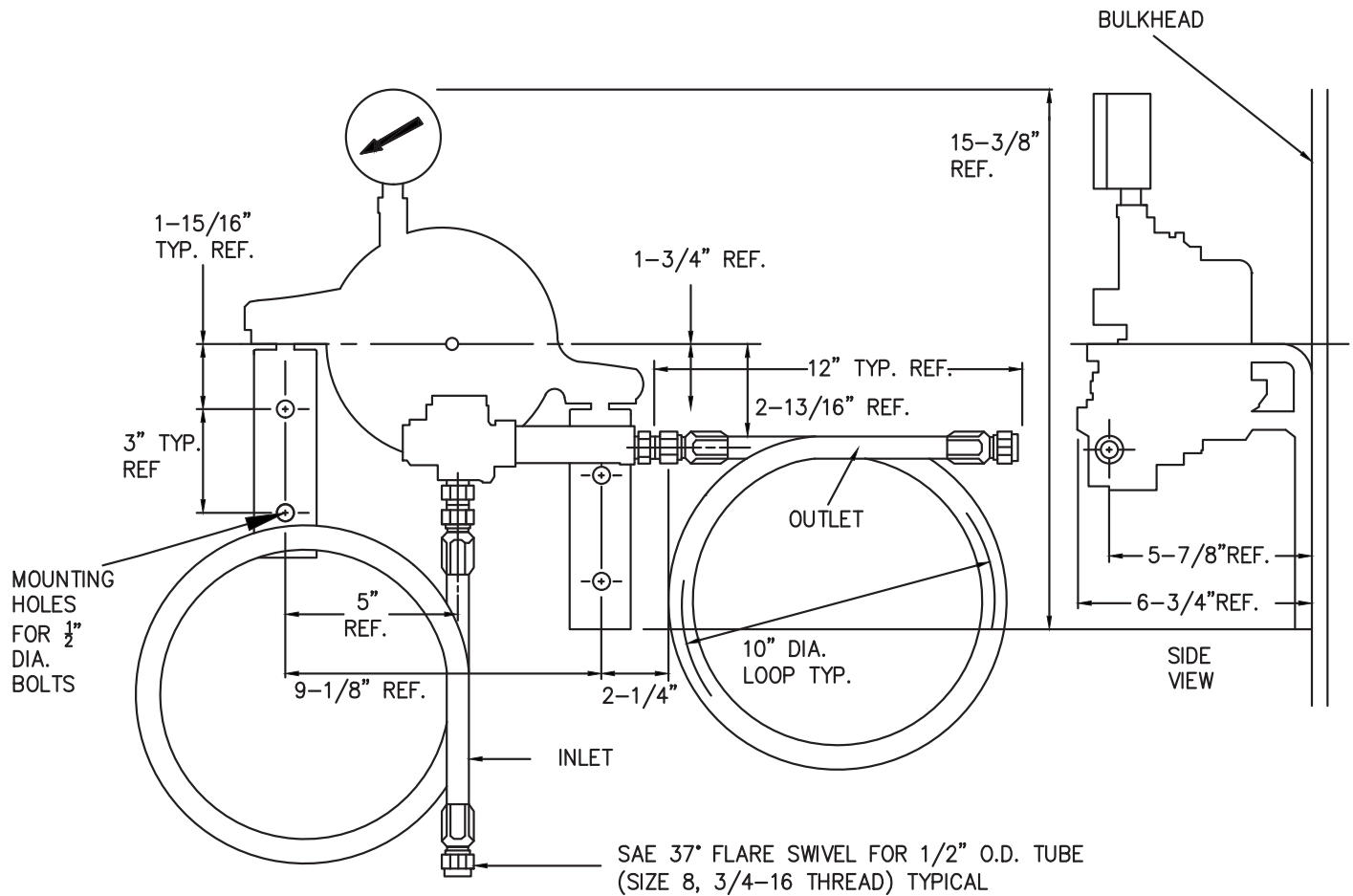



Part Number 1124152

Flex Hose

- Hose Assembly Overall Length: 44"
- Hose: 1/2" Synthetic Rubber Reinforced
- Fitting: SAE 37° Flare Swivel for 1/2" OD Tube (Size 8, 3/4-16 Thread)
- Maximum Burst Pressure: 2500 psi
- Operating Temperature Range: -40° F to +200° F
- Minimum Bend Radius: 4.62"
- Hydrostatic Test to twice rated working pressure. Pressure shall be held for at least one minute and no more than five minutes.

Hose, Fittings & Testing meet NAVSEA 0901-LP-833-0004 • Chapter 9480

Service requires replacement at five year intervals per Section 9480.165 • Reference: NAVSEA Letter No. 9555 Ser.56Y34/465 • Dated July 19, 1984 & BUSHIPS Dwg. No. 124-300 (5201-S48803-28

Formerly P/N 124-52

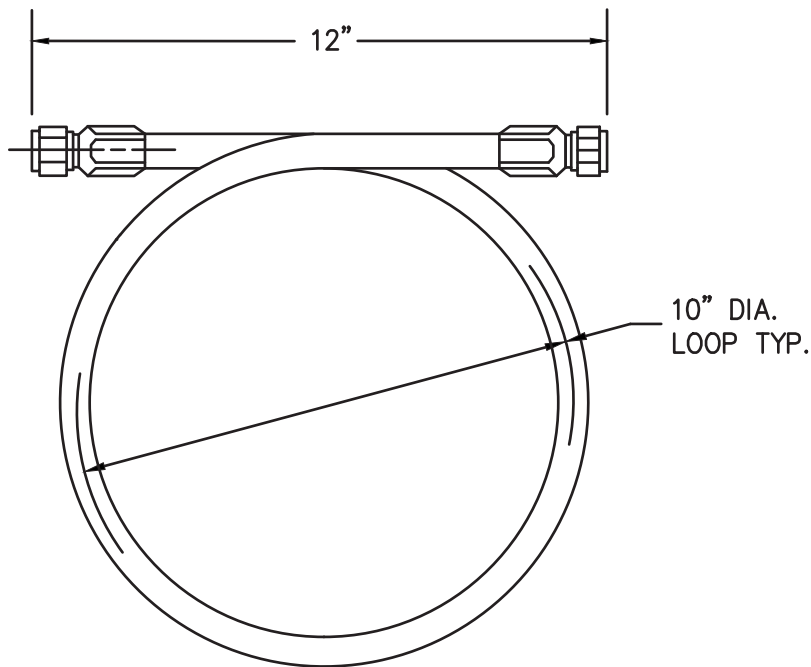

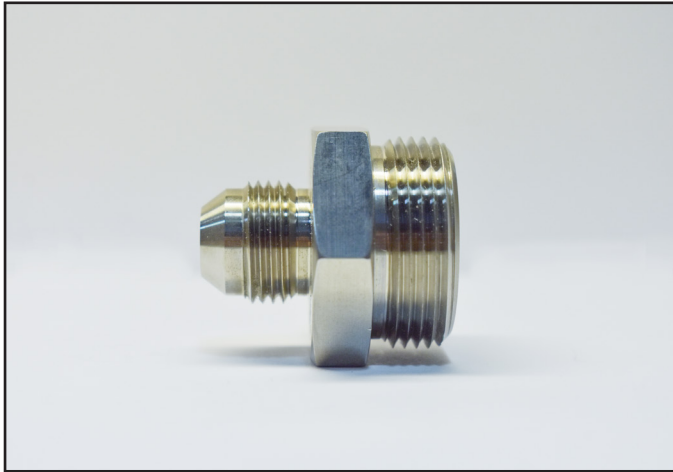

Part Number 8124155

Hose Adapter

3/8" NPT Union to 1/2" Tube

The Hose Adapter is available for connecting hose assemblies to a PRPV having brazed union joints.

Material: Monel ASTM B164,
Alloy No. 4405 Cold Drawn 1-3/8 Hex

Formerly P/N 124-55

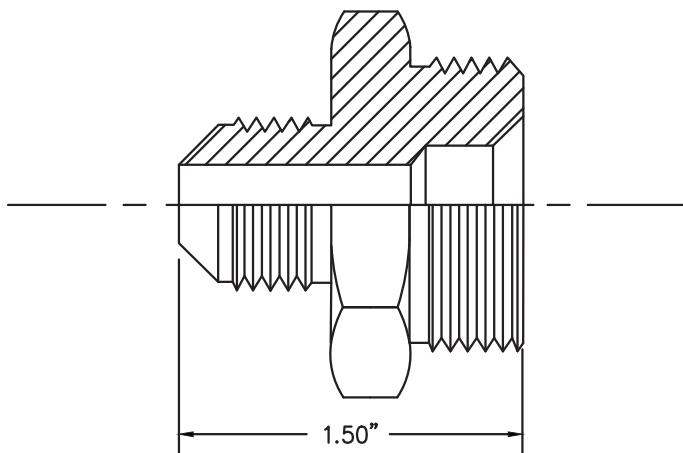

Vented Check Valve (VCV)



Part Number 8124706

Vented Check Valve (VCV)

NSN Number 4210-00-399-2532

Vented Check Valves are installed in the thermo-pneumatic system to prevent air from returning into the thermo-detection system.

Formerly P/N 124-1000A

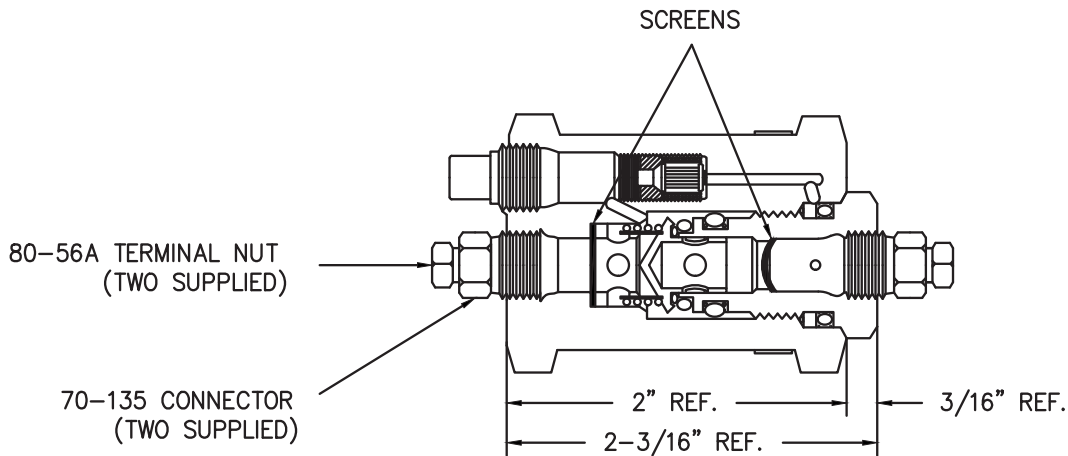

Vented Check Valve Bracket



Part Number 8124105

VCV Bracket (4 Position)

3/8" NPT Union to 1/2" Tube

This Vented Check Valve & Bracket Assembly has passed the requirements of MIL-S-901C, Navy High Impact and MIL-S-167-1, Mechanical Vibrations of Shipboard Equipment.

Note: Cap screws will accommodate 3/4" Maximum Bulkhead

Formerly P/N 124-1050

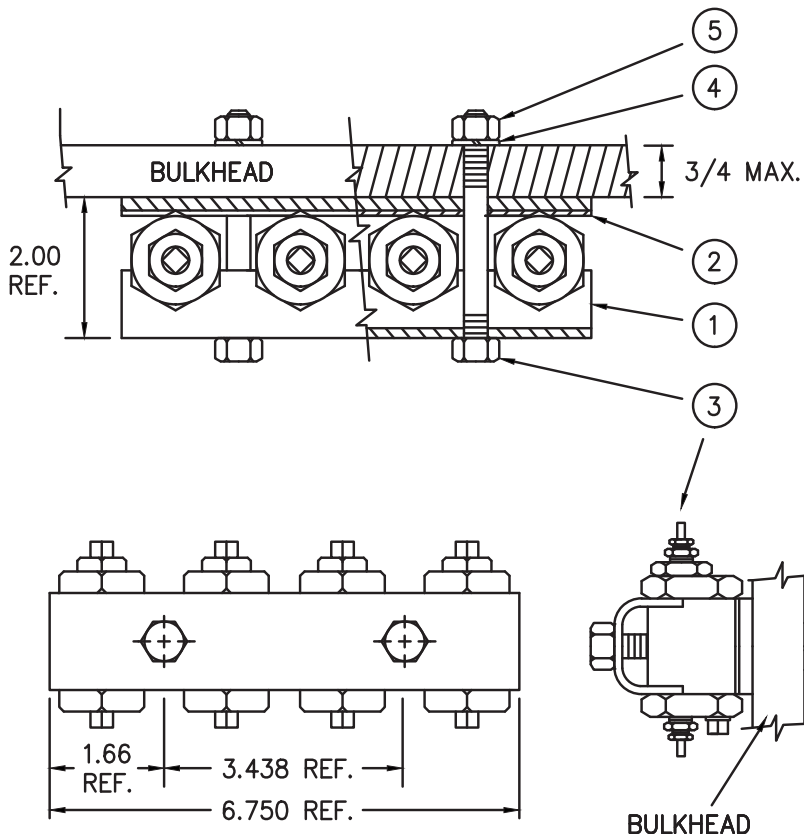
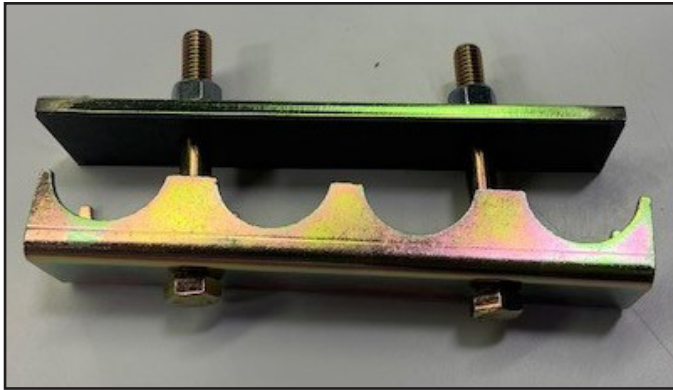

Legend:

- 1- Channel, Plated Steel
- 2 - Backing Bar Subassembly, Plated Steel
- 3 - 3/8-16 LG. Hex Head Cap Screw (2 supplied)
- 4 - 3/8 Lockwasher (2 supplied)
- 5 - 38-16 NC Hex Nut (2 supplied)

Heat Sensing Device (HSD)



Part Number 8169150

Heat Sensing Device - 165° F Link Type

NSN Number 4210-00-111-7020

The Heat Sensing Device is designed to detect heat from fire and actuate the thermo-pneumatic system.

NAVORD Dwg. No. 2544987

Formerly P/N 124-150

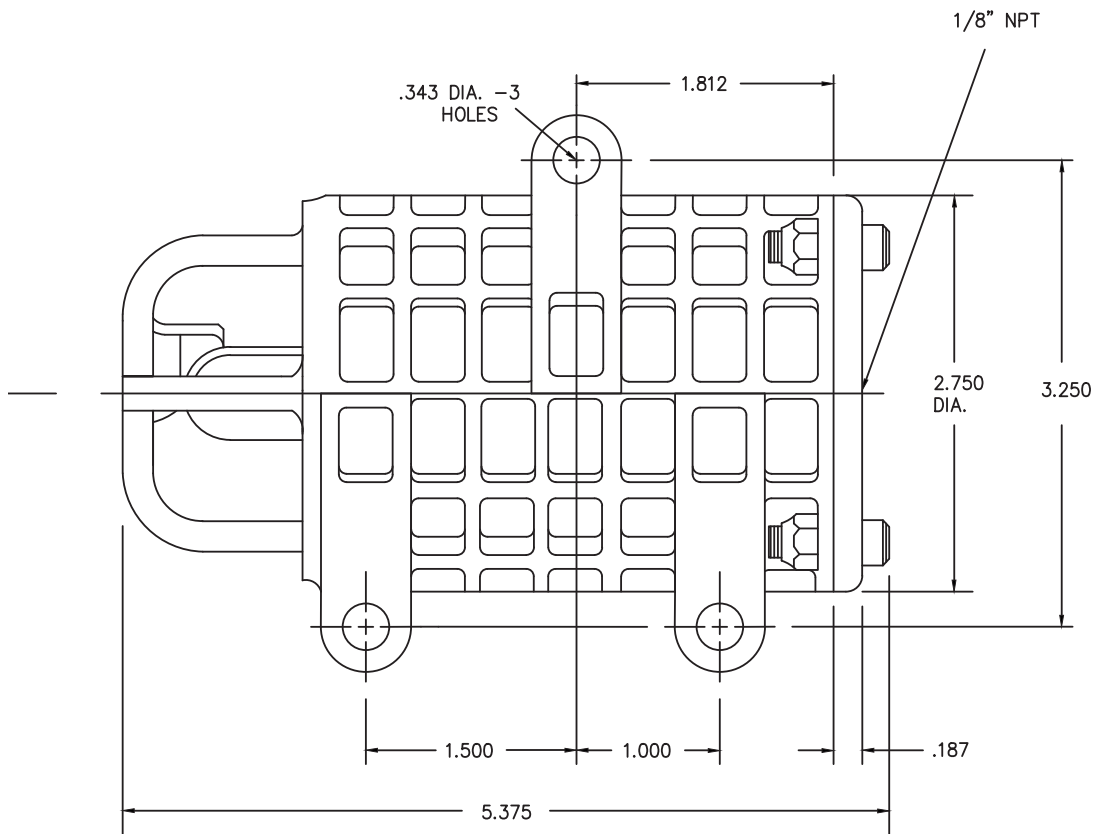



Rockhide Tubing

100 ft Coil

1000 ft Coil

Part No

8084645

8084646

Rockhide Tubing is used to connect the various components of the thermo-pneumatic system. Rockhide Coated Tubing is the Navy approved replacement for Rockbestos Covered Tubing.

NSN Number 4710-00-039-5702

*Reference: NAVSEA Letter No 5334/RR
Ser. 80 • Dated February 21, 1982*

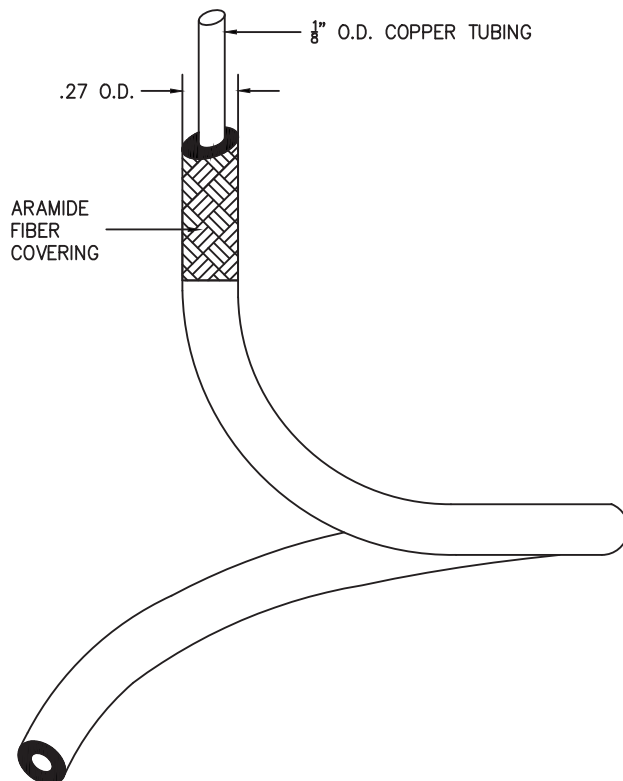



Part Number 8124550

Tool Set (HSD Circuit)

This Tool Kit contains the necessary tools for installing and making emergency repairs to the thermo-pneumatic system.

NSN Number 5810-00-343-2016

Formerly P/N 124-550

QUANTITY	DESCRIPTION	PRPV P/N	FORMER P/N
1	Leak Detector	1601697	-
2	Flaring Tools	8109005	109-124
2	Wrenches	1109119	109-119
1	File	1600789	-
1	Instruction Sheet	-	-
1	Box	1124551	124-551

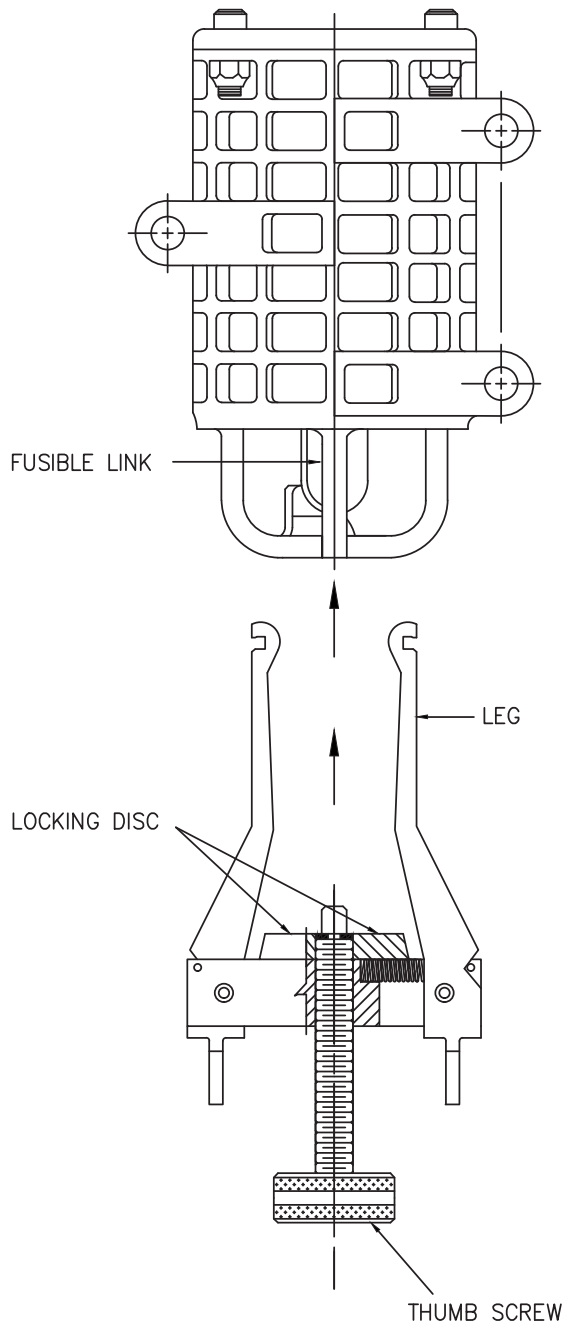

Part Number 8169170

Link Installation Tool

Installing Links in the Heat Sensing Device (HSD)

Turn the thumb screw out (as shown in the diagram). Insert the installation tool and hook the leg notches into the holes at the end of the bellows. Turn the thumb screw in to extend the bellows and compress the spring. Turn the locking disc in to keep the legs from slipping out of the holes. Continue turning the thumb screw in until the link can be slipped over the hooks. Slip the link over the hooks using needle nose pliers or tweezers. Turn the thumb screw and locking disc out to remove the tool.

Formerly P/N 169-170

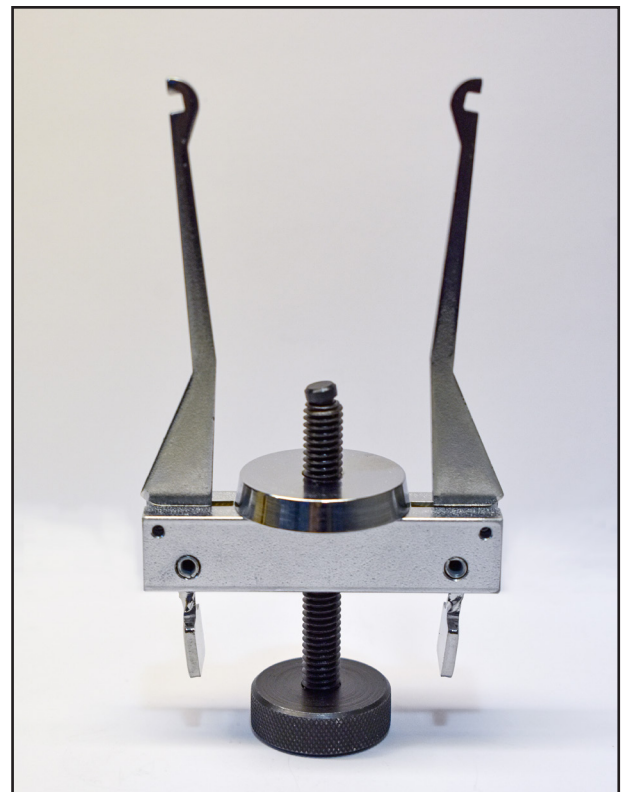

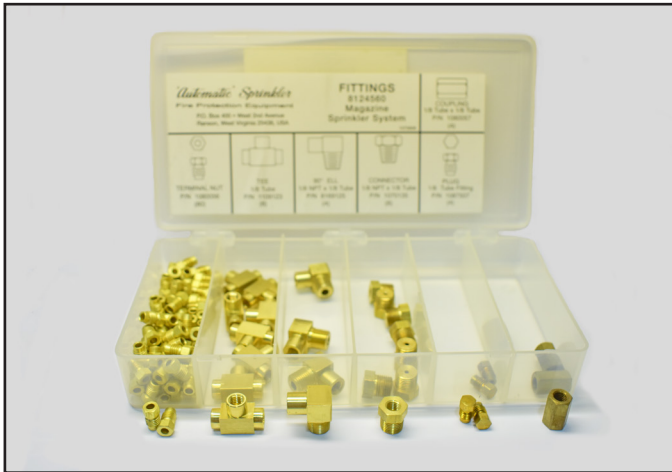

Part Number 8124560

Fittings Assortment

This kit contains an assortment of replacement fittings for use in the thermo-pneumatic system. Individual fittings can be ordered separately using the PRPV P/N shown below in the table.

Formerly P/N 124-560

QUANTITY	DESCRIPTION	PRPV P/N	FORMER P/N
80	Terminal Nuts	1080056	80-56A
8	Tees, 1/8" Tube	1109123	109-123A
4	90° Ells, 1/8" NPT x 1/8" Tube	8169125	169-125
8	Connectors, 1/8" NPT x 1/8" Tube	1070135	70-135
4	Couplings, 1/8" Tube x 1/8" Tube	1080057	80-57A
4	Brass Plugs, 1/8" Tube Fitting	1087507	87-507
1	Identification & Order Sheet	-	-
1	Box	1124561	124-561

Fittings for Thermo-Pneumatic Detection System



8169142
Street Tee
(HSD Test Fitting)



8169141
Male Branch Tee
(HSD Test Fitting)

Fittings for Thermo-Pneumatic Detection System

All fittings are inverted flare type. Inverted flare fittings meet the requirements of NAVSEA 03487-078-1000.



8084610
1/8" Tubing Tee with Terminal Nuts
(Used between VCV and PRPV Manifold)



8084624
1/8" NTP x 1/8" Tubing
90° Ell with Terminal Nut
(Used on HSD)

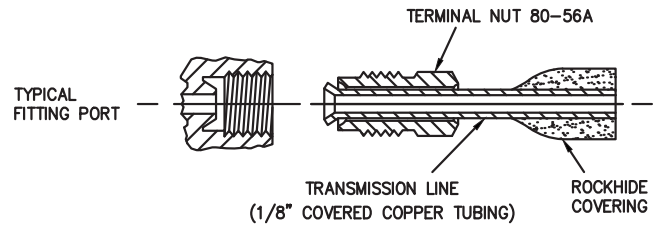

1080056
1/8" Terminal Nut
(Used with all fittings)



1080057
1/8" Tubing Coupling with Terminal Nut
(Used to make emergency tube splices)



8084623
1/8" NTP x 1/8" Tubing Connector with Terminal Nut
(Used on HSD and VCV)



Part Number 8169161

**Manually Operated Pulse Generator
with Connecting Hose**

The Pulse Generator is designed to simulate the action of the heat sensing device when testing the thermo-pneumatic fire protection system.

NAVSEA Approved

Reference: NAVSEA Letter No 9555

Ser. 56Y5/16 • Dated June 28, 1985

Formerly P/N 169-161

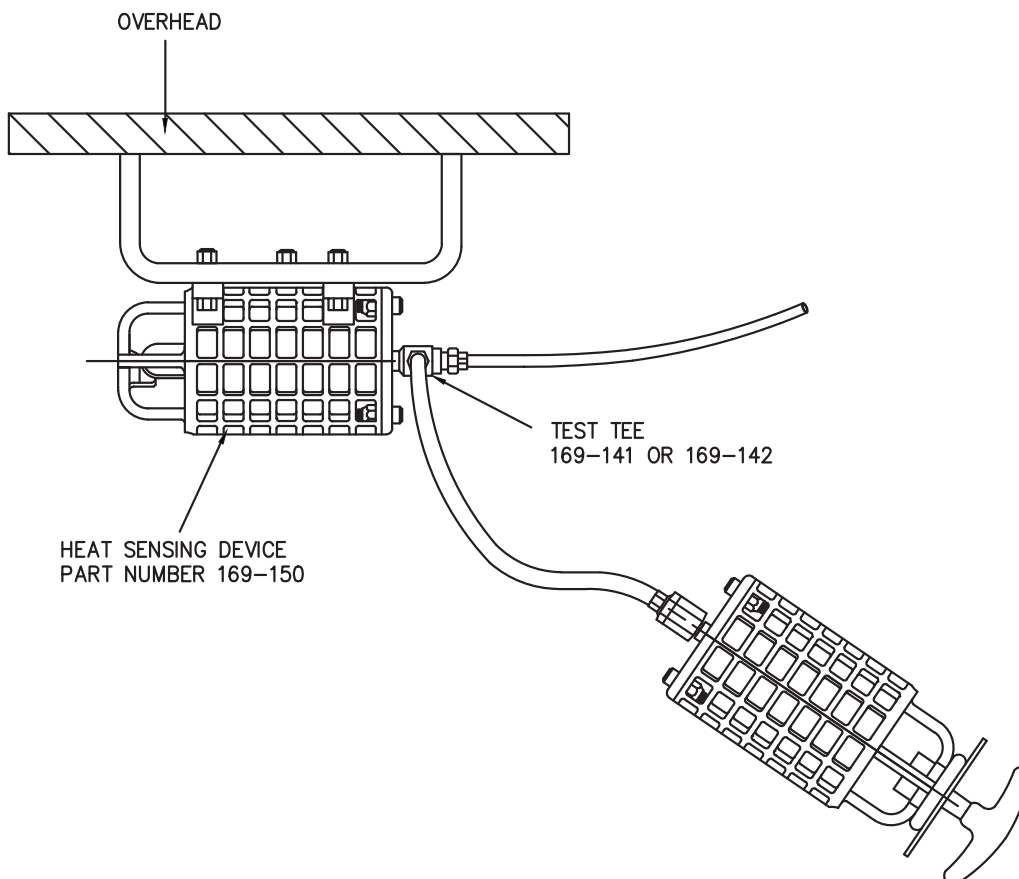

Manometer (Large & Small)



Part Number 8069701

18" (Large) Manometer

The large manometer is used to verify the tightness of the thermo-pneumatic system tubing. The large manometer is also used to check the pressure required to operate the PRPV.

Formerly P/N 69-100A

Part Number 8068701

9" (Small) Manometer

The small manometer is used for measuring the PRPV and vented check valve compensating vent ratings. The small manometer is also used to verify the pressure at which the vented check valve opens.

Formerly P/N 69-100B

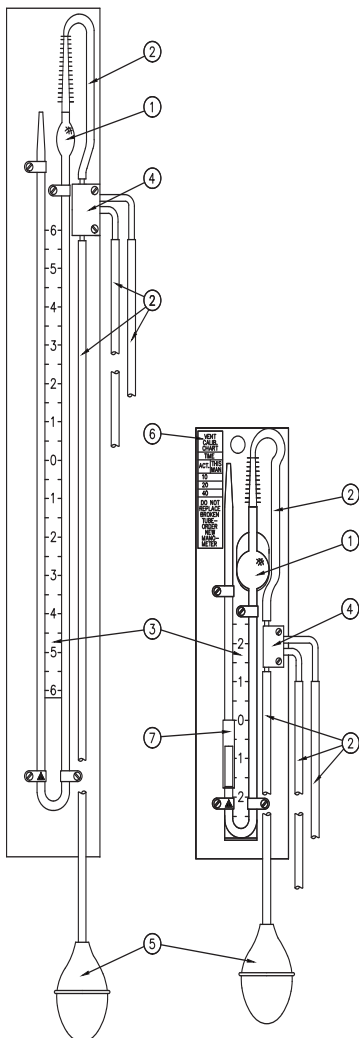

Legend

- 1 - Glass U-Tube
- 2 - Rubber Tubing
- 3 - Scale
- 4 - Manifold
- 5 - Rubber Bulb
- 6 - Vent Calibration Chart
- 7 - Sight Slide



Part Number 1408101

Air Gauge, 36 oz, White Face with Black Markings

NSN Number 668501-260-7933

Formerly P/N 79-861



Part Number 1408105

Air Gauge, 36 oz, Black Face with White Markings



Part Number 8124048

Reset Key for PRPV

This component is required for resetting an actuated PRPV valve. The key fits over the square lug in the center of the PRPV valve.

Formerly P/N 134-307



The responsibility of the proper operation of the magazine sprinkler system lies primarily with ships force, once the ship leaves the yard. In order to perform this task, guidelines which have been taken from NAVSEA 078-1000 and the PMS cards should be followed.

Note: At no time is it approved to enter the PRPV for internal adjustments or repairs. Contact PRPV Industries, LLC at (800) 220-2023 or info@prpvind.com for a technical representative and/or field assistance.

SECTION A - Air Tightness Test

- A.1 Ensure that all test castings have been installed in the magazine sprinkler valves
Note: It is possible that more than one space may discharge, install all test castings in hold.
- A.2 Secure the salt water supply root cut-out valve to PRPV.
- A.3 Remove cover from Schrader valves on the face of PRPV and connect a hand operated pump.
 - A.3.1 The PRPV must be in the set position
- A.4 Using the hand operated pump, pressurize the system until stable at 8oz per square inch on the 36 oz gauge. **Warning:** While pressurizing do not allow the gauge needle to exceed 24oz
 - A.4.1 Remove the pump and allow the system to stabilize.
 - A.4.2 Large systems may require multiple pressurizations.
- A.5 Pressure on the system may exceed 8oz after stabilization. If this condition exists, pressure may be relieved slowly by loosening the test fitting on the manifold. Do not completely remove the test fitting. The system must be allowed to stabilize completely after each release.
- A.6 Maintain a minimum 8oz of system air pressure for a maximum of 5 minutes.
 - A.6.1 If the system leaks air, utilize a mixture of soap/water to detect leak.
 - A.6.1.1 Repair all leaks (see repair instructions)
 - A.6.1.2 Continue to pressurize until 8oz can be maintained for a minimum of 5 minutes.



SECTION B - Functional Test of Thermo-Pneumatic System

- B.1 With 8oz of system pressure, fully depress the Schrader valve. This action should trip the PRPV. If the PRPV does not trip, repeat pressurization steps and retrip.

Note: If the PRPV does not trip on the second attempt, notify the person in charge of space to acquire technical assistance or a replacement valve.

- B.2 Replace the cover on the Schrader valve
- B.3 Remove test castings from magazine sprinkler valves
- B.4 Open salt water root cut-out valve
- B.5 Visually check all thermal lines for crimped lines
- B.6 Visually check all heat sensing device (HSD) fusible links for secure hold.

Note: If an attempt is made to reset a PRP valve that has not been completely relieved of air pressure, a half/set condition may be a result. The fix for this condition is as follows:

- B.6.1 Pressurize the system with all safety requirements in place and trip the Schrader valve.
- B.6.2 Completely exhaust the system prior to reset and remove safety devices.

SECTION C - Repair Instructions

It may be necessary to make repairs due to air leaks in the system. Utilize repair kits PRPV Part No. 8124560 and Part No. 8124550 to perform these repairs.

- C.1 Strip the Rockhide covering from the tubing, not more than 1-1/2" from the end, using a standard knife as you would sharpen a pencil. Do not cut the covering using a circular method as this results in ring cuts.
- C.2 Put a terminal nut onto the tubing backwards so that the flat end of the nut is towards the end of the tubing.
- C.3 Using a fine file, file the end of the tubing flat against the back of the nut. Point the tubing end downwards to keep filing material out of the tubing.
- C.3.1 Remove the terminal nut, lightly remove any burrs from the edges with a file.
- C.4 Replace terminal nut with the 37° flat end towards the end of the tubing.
- C.5 Insert the flaring tool and, with a circular motion, make an even flare. Pointing the tube end downwards, tap on the terminal nut with the flaring tool to remove any filing material.
- C.6 Reinstall the fitting taking care not to cross-thread the nut during installation.

Warning: Do not use a tube cutter at any time.

Note: System must be checked for air tightness after all leaks have been repaired.



SECTION D - Pulse Generator Test

When using the Pulse Generator Part No. 8169161, follow the procedure below:

- D.1 Remove the cap from the T-fitting on the front of the HSD
- D.2 Pull the handle on the pulse generator back and place it in the set position
Warning: The pulse generator must be in the set position prior to the next step of the PRPV may be damaged.
- D.3 Attach flex hose to the Schrader valve connection on the T-fitting of the HSD
- D.4 Release the plunger rod. The PRPV should trip.

Note: If the PRPV does not trip - relieve pressure from the PRPV using the test connection on the manifold. Repeat the test again using the above procedure. If the second attempt fails, contact PRPV Industries, LLC at (800) 220-2023 or info@prpvind.com for a technical representative and/or field assistance

- D.5 Trip each HSD in the system for a complete test.

Note: Relieve pressure from the PRPV after each HSD is tested in the system.